

MODEL # MO-61-IN

INSTALLATION GUIDE



COOK^N DINE

BUILT-IN ULTRADINE
PLUS COOKTOP

- Electrical Rating: 240V | 2250 Watt | 10 AMP | 50-60 Hz
- 2.25 kWh on high
- Always check control box label for correct voltage before plugging in.

IMPORTANT:

- Do not drill nor cut any holes before unit is physically present
- Do not cut off the bolts
- Do not open control box or warranty expires

Preparation for kitchen-top for flush-mount assembly

1. Prepare kitchen-top as shown in the following drawing by CNC milling or a similar process:

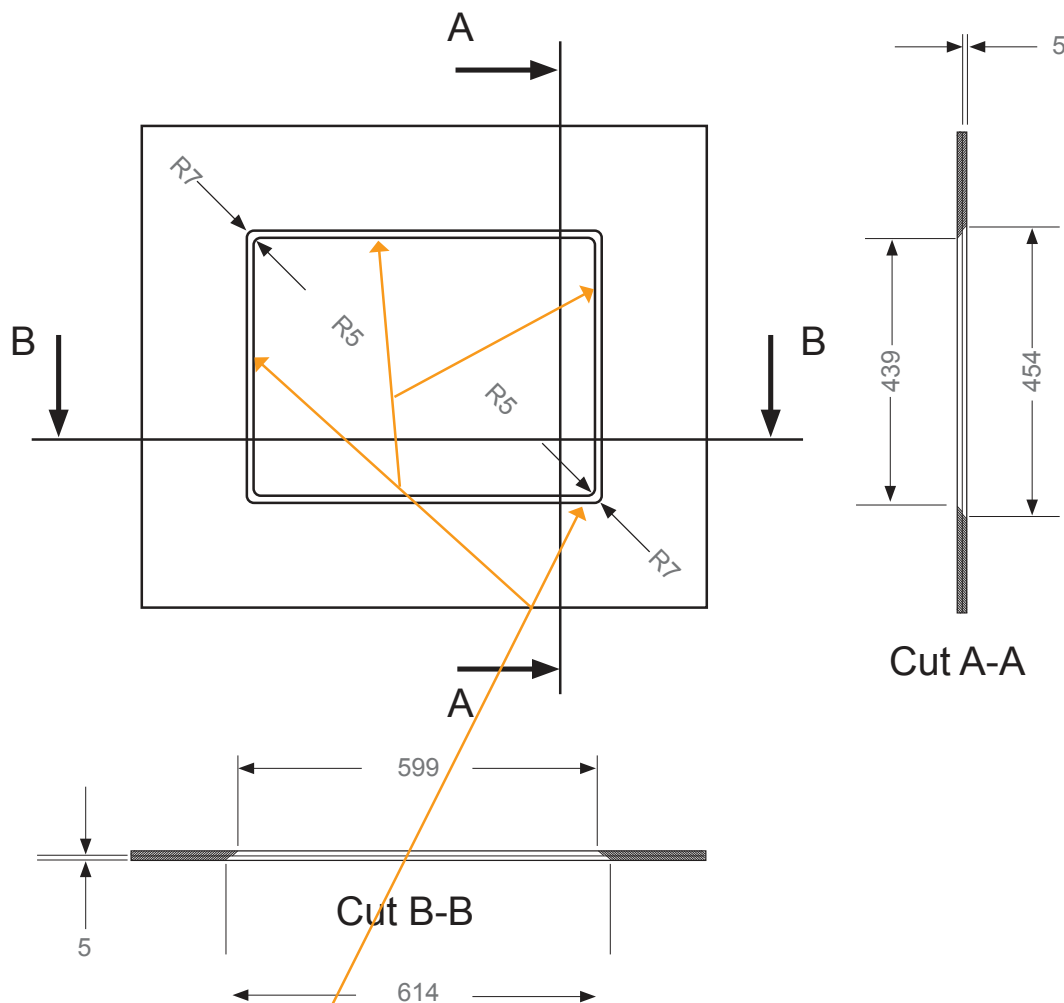

2. Clean underside edges of unit and counter top around cut out with rubbing alcohol or similar
3. Attach a 2mm thick sealing tape (example see picture below) that is suitable for kitchen appliances on this surface

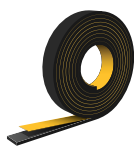

4. Insert the Teppanyaki in the cut-out in the kitchen-top, right in the centre, so that a consistent 2mm gap is created between the kitchen-top and the Teppanyaki plate
5. Fill this gap by a kitchen silicone
6. Assemble control unit as shown on the next page
7. Wait at least 48 hours until your switch on the unit.

BUILT-IN ULTRADINE PLUS COOKTOP

MODEL # MO-61-IN

Install Sheet 2 of 4

- Electrical Rating: 240V | 2250 Watt | 10 AMP | 50-60 Hz
- 2.25 kWh on high
- Always check control box label for correct voltage before plugging in.

IMPORTANT:

- Do not drill nor cut any holes before unit is physically present
- Do not cut off the bolts
- Do not open control box or warranty expires

Preparation for kitchen-top for top-mount assembly

1. Prepare kitchen-top as shown in the following drawing by CNC milling or a similar process:

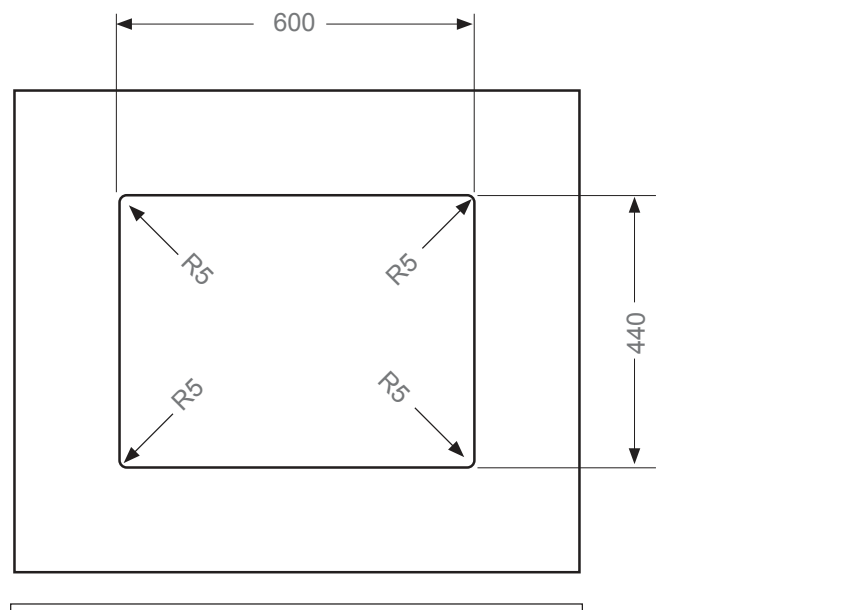

2. Clean underside edges of unit and counter top around cut out with rubbing alcohol or similar
3. Attach a 1mm thick sealing tape (example see picture below) that is suitable for kitchen appliances on this surface
4. Insert the Teppanyaki in the cut-out in the kitchen-top, right in the centre
6. Assemble control unit as shown on the next page

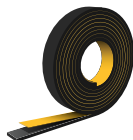

BUILT-IN ULTRADINE PLUS COOKTOP

TYPE "B"
CONTROL BOX
CONCEALED
MOUNT

Install Sheet 3 of 4

CAUTION: Do not snap, pull or twist the conduit during installation.

Warranty will expire if capillary tube inside the conduit is damaged during installation.

Control box must be firmly fastened to a non-moving surface.

IMPORTANT: Do not open the control box or warranty expires.

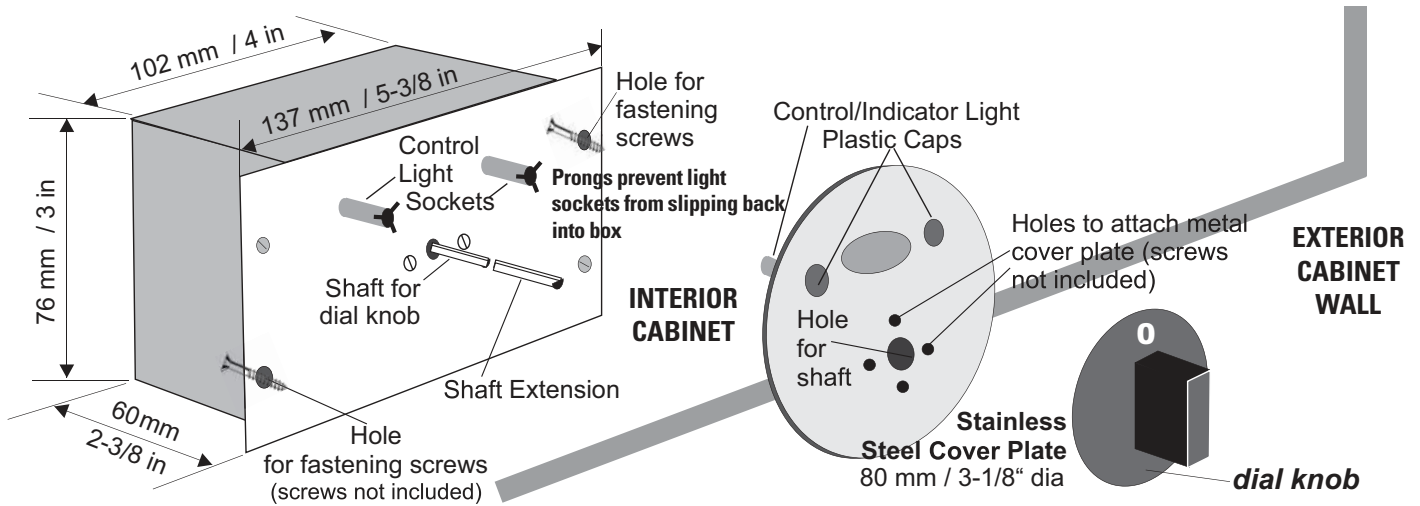

DIRECTIONS

1. Remove packaging and carefully pull off the dial knob only while holding on to the round plate. Do not use force or tools.
2. Now separate the round steel plate from Control Light Sockets by carefully wiggling it away with the yellow and green light plastic caps. Hold one with two fingers and gently pull plate away; repeat with other. Yellow and green plastic caps stay in place in the plate.
3. Mark all necessary holes utilizing the provided template below. Drill required holes and gently thread light sockets through their designated openings. Do not snap the prongs. Now fasten the box to interior of cabinet wall or underside of counter top.
4. Gently pull light sockets out a little bit and re-connect with plastic caps in the metal plate; affix plate with two small flathead screws, or silicone into place.
5. Connect the hollow extension to shaft if needed (packed with nuts + washers). Slide dial knob onto stem (match flat side of stem with flat side of female receptacle at back of knob). Do not use force.

CAUTION: Do not twist or snap delicate white wiring of indicator lights.

BUILT-IN ULTRADINE PLUS COOKTOP

TYPE "B"
CONTROL BOX
CONCEALED
MOUNT

IMPORTANT: To use as 1:1 template set "page scaling" to "none" when printing.

Install Sheet 4 of 4

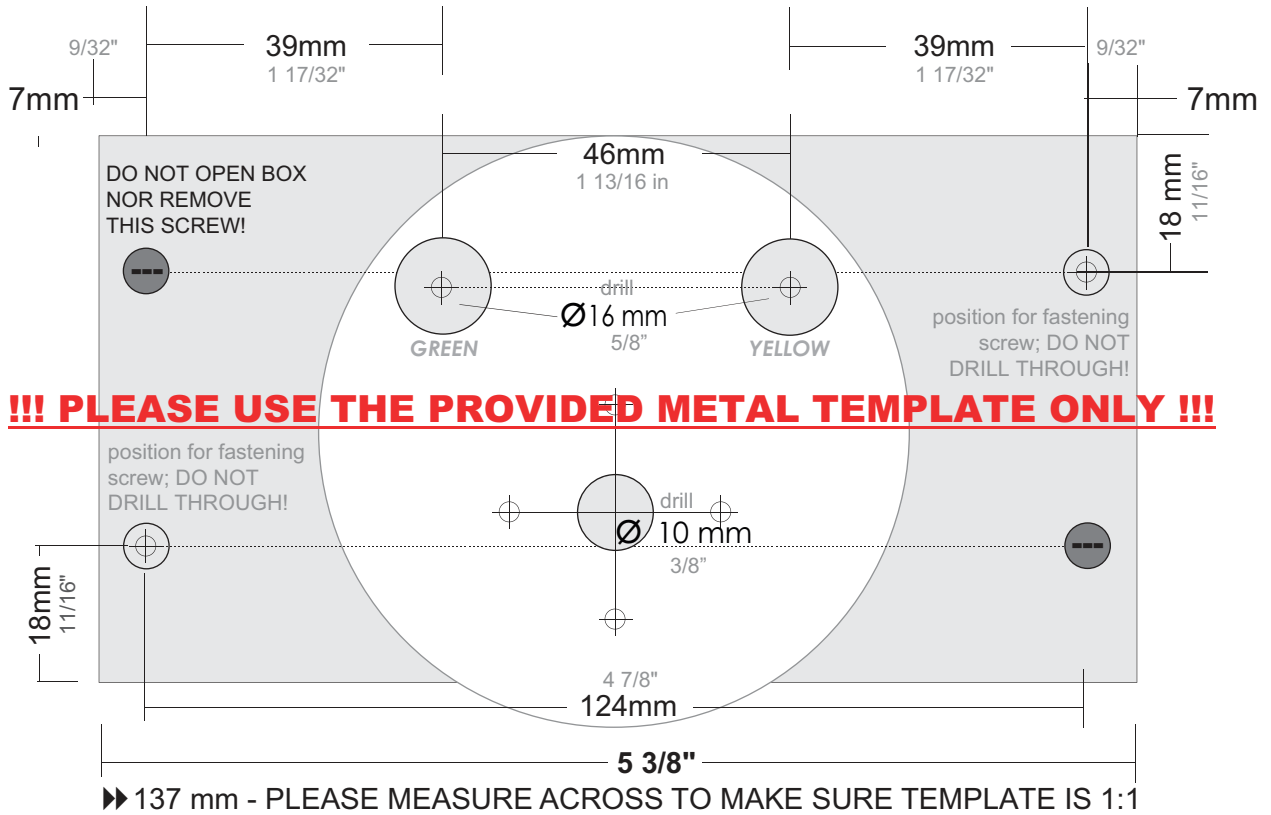

!!! PLEASE USE THE PROVIDED METAL TEMPLATE ONLY !!!

- NOTE:
- If the external cord/cable is damaged, it shall be exclusively replaced by the manufacturer or his service agent or a similar qualified person in order to avoid a hazard.
 - This appliance is not intended for use by persons (including children) with reduced physical, sensory or mental capabilities, or lack of experience and knowledge, unless they have been given supervision or instruction concerning use of the appliance by a person responsible for their safety
 - Children should be supervised to ensure that they do not play with the appliance.
 - Warning: Accessible parts may become hot during use. Young children should be kept away.